

Prona

R-4300(S)-S/P SPRAY GUN

OPERATING

PARTS LIST

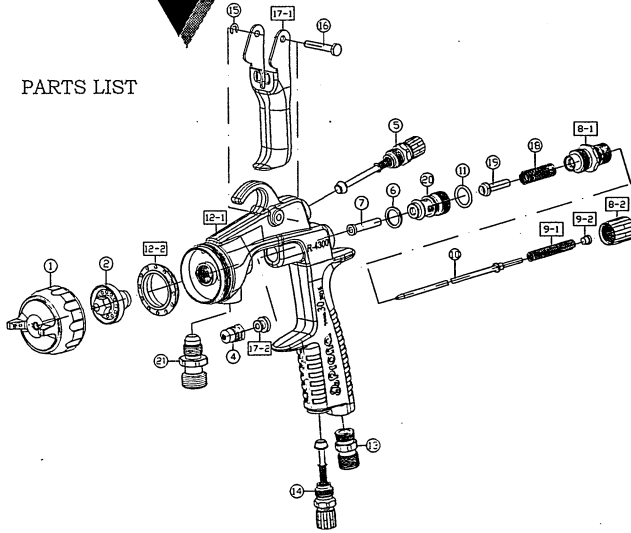

NO	Description	Q'ty
1	Air cap set	1
2	Fluid nozzle set	1
4	Fluid needle packing screw set	1
5	Pattern adjusting set	1
6	Fluid needle guide packing	1
7	Fluid needle guide	1
8-1	Fluid adjusting knob guide set	1
8-2	Fluid adjusting knob	1
9-1	Fluid needle spring	1
9-2	Fluid needle spring gasket	1
10	Fluid needle set	1
11	O ring	1
12-1	Gun body	1
12-2	Distributary cap	1
13	Air connector	1
14	Air adjusting set	1
15	Locking ring	1
16	Trigger stud	1
17-1	Trigger	1
17-2	Trigger guide	1
18	Air valve spring	1
19	Air valve	1
20	Air valve seat set	1
21	Fluid connector	1

Prior to operation read the operating instructions carefully.

OPERATION

The SPRAY GUN has been designed as a HAND HELD, AIR OPERATED TOOL, and in the interests of safety must only be used for the purpose for which it has been designed. The tool should on no account be used for any other purpose for whatever reason, this could result in danger to the operator and those within the immediate working area.

The Spray Gun should be connected to a clean air supply using the recommended fittings and hose size as specified in the diagram. Whenever possible there should be an air filter & regulator in the system as diagram. The recommended pressure at the tool should measure 60 psi while running free. Check fittings and hoses regularly for signs of fraying, or accidental damage. Replace any worn items before continuing to operate the Spray Gun. Always connect the cup and the air hose tightly to the Spray Gun before use. Ensure the material and air supply are disconnected before effecting any work on the Spray Gun.

ADJUSTMENT

To obtain the required spraying pattern, volume of fluid and degree of atomisation, use the Pattern Adjusting Knob, Air Adjusting Knob and the Fluid Adjusting Knob.

- To Adjust the Pattern-Turn the Pattern Adjusting Set to the Right to narrow the spray pattern and to the left to widen the spray pattern.
- To Adjust the Fluid Output-Turn the Fluid Adjusting Knob to the Right to reduce the fluid output and to the Left to increase the fluid output. Turning the Fluid Adjusting set fully to the Right will stop the fluid completely, the spray gun will then only emit air.
- To Adjust the Air Volume-Turn the Air Adjusting Set to the Right to reduce the air volume and to the Left to increase the air volume.
- The recommended air pressure is 2.0-2.5 bar (29-36 psi). Recommended spray distance to object is 15-20 cm (6-8 inches).
- Recommended material viscosity is 20 seconds /Ford#2. It differs according to material property and spraying conditions.

