

Prona

R430 SPRAY GUN

OPERATING I

PARTS LIST

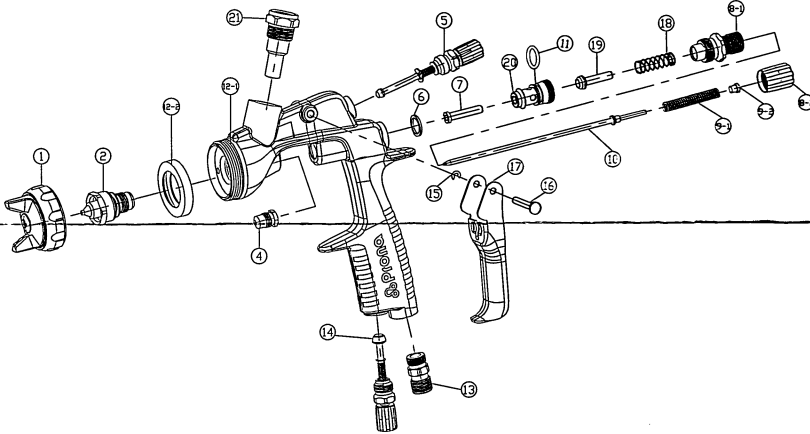

No.	Description	Qty
1	Air cap set	1
2	Fluid nozzle	1
4	Fluid needle packing screw set	1
5	Pattern adjusting set	1
6	Fluid needle guide packing	1
7	Fluid needle guide	1
8-1	Fluid adjusting knob guide set	1
8-2	Fluid adjusting knob	1
9-1	Fluid needle spring	1
9-2	Needle spring gasket	1
10	Fluid needle set	1
11	O-ring	1
12-1	Gun body	1
12-2	Connector washer	1
13	Air connector	1
14	Air adjusting set	1
15	Locking ring	1
16	Trigger stud	1
17	Trigger	1
18	Air valve spring	1
19	Air valve	1
20	Air valve seat set	1
21	Fluid connector	1

Prior to operation read the operating instructions carefully.

OPERATION

The SPRAY GUN has been designed as a HAND HELD, AIR OPERATED TOOL, and in the interests of safety must only be used for the purpose for which it has been designed. The tool should on no account be used for any other purpose & whatever reason, this could result in danger to the operator and those within the immediate area.

The Spray Gun should be connected to a clean air supply using the recommended fitting and hose size as specified in the diagram. Whenever possible there should be an air filter & regulator in the system as diagram. The recommended pressure at the tool should measure 60 psi while running free. Check fitting and hoses regularly for signs of fraying, or accidental damage. Replace any worn items before continuing to operate the Spray Gun.

ADJUSTMENT

Always connect the cup and the air hose tightly to the Spray Gun before use. Ensure the material and air supply are disconnected before effecting any work on the Spray Gun.

To obtain the required spraying pattern, volume of fluid and degree of atomisation, use the Pattern Adjusting Set, Air Adjusting Set and the Fluid Adjusting Screw.

This spray gun has been developed to operate with low air pressure comparing with the conventional spray guns. The recommended atomising air pressure is 2.0-3.0 bar (29-43 psi). Excessive atomising air pressure can increase overspray, reduce transfer efficiency.

The recommended spray distance is 20-25cm (7.9-9.8 in). Good finishing will not be obtained if the spray distance is too far. The recommended material viscosity is 15 - 23 seconds / Ford#4.

